

LOC	DIST	REVISIONS					
G	14	P	LTR	DESCRIPTION	DATE	DWN	APVD
			F6	REVISED PER ECO-14-015173	08OCT2014	NK	DR

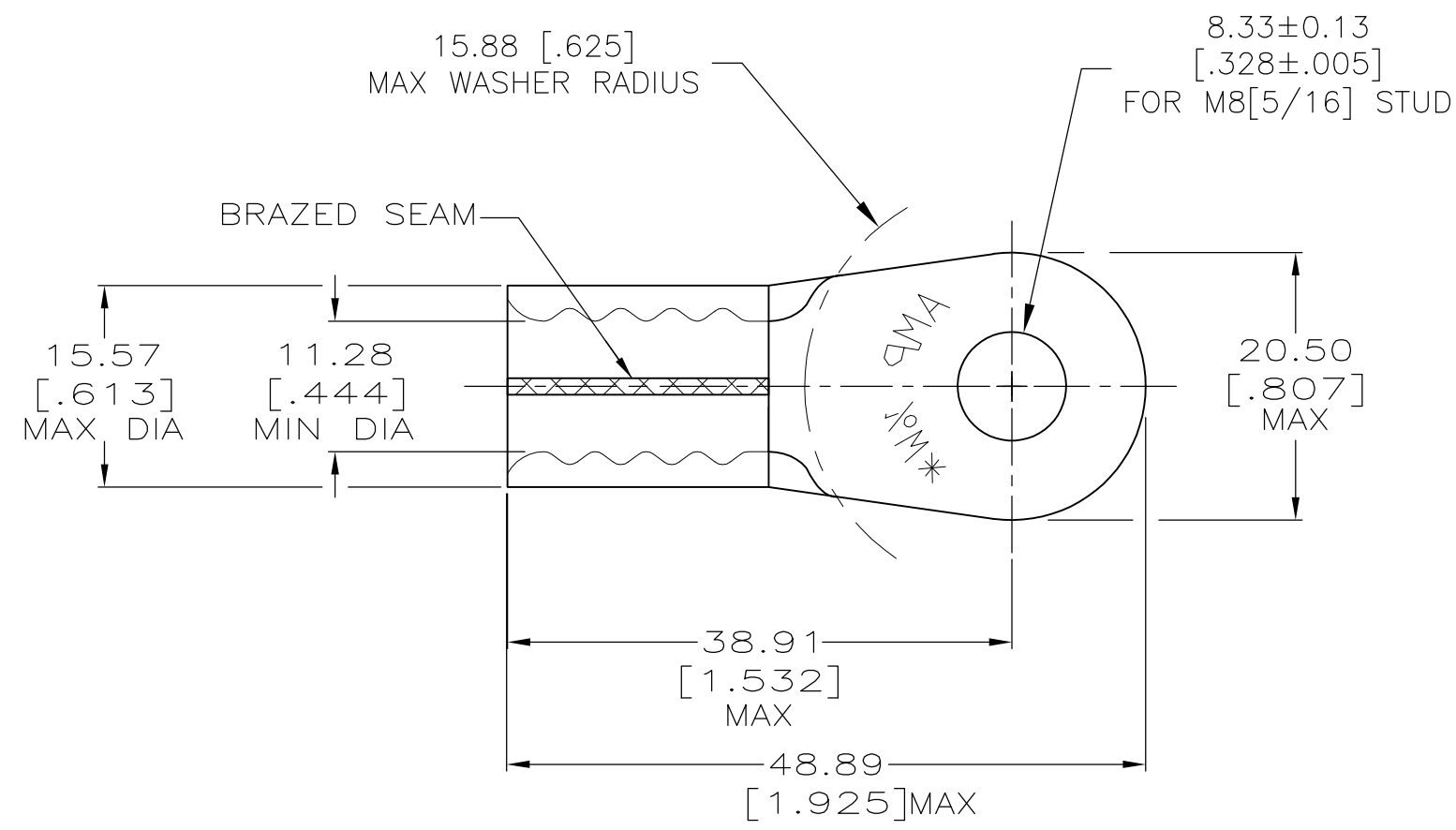

AMP WIRE RANGE	E13288 Listed
1/0 AWG SOLID OR STRANDED	1/0 AWG SOLID OR STRANDED
LR7189 Certified	MILITARY P/N AND CLASS
1/0 AWG SOLID OR STRANDED	

- TIN PL 0.00254[.000100] MIN THK PER ASTM B-545
- NICKEL PLATE 0.00762 [.000300] MIN EXT. THK PER QQ-N-290
- MS20659-151 CLASS 2
- 4 MATERIAL THICKNESS: 1.78±0.08[.070±.003]
- GOLD PLATE 0.00127[.000050] MIN EXT. THK. PER ASTM B488, TYPE 1, CODE C OVER NICKEL PLATE 0.00127[.000050] MIN. EXT. THK PER SAE AMS QQ-N-290 OVER Cu FLASH PER SAE AMS 2418

170°C [338°F]	25	LOOSE PIECE		8-321867-3
260°C [500°F]	50	LOOSE PIECE		321867-3
343°C [649°F]	50	LOOSE PIECE		321867-2
170°C [338°F]	50	LOOSE PIECE		321867
MAX TEMP RATING	QTY	PACKAGE TYPE	FINISH	PART NO.

MAX RECOMMENDED OPERATING TEMPERATURE: SEE TABLE	THIS DRAWING IS A CONTROLLED DOCUMENT.		DWN 8/30/91 DK SCHRUM		TE Connectivity
	VOLTAGE RATING: N/A	DIMENSIONS: mm[INCHES]	TOLERANCES UNLESS OTHERWISE SPECIFIED: 0 PLC ± - 1 PLC ± - 2 PLC ± 0.20[.008] 3 PLC ± - 4 PLC ± - ANGLES ± -	CHK 9/30/91 RD HEIM	
CIRCULAR MIL AREA: 42.4-60.6mm² [83,700-118,500]				MATERIAL COPPER PER ASTM B152 ANNEALED	FINISH SEE TABLE
	PRODUCT SPEC -	CAGE CODE 00779	DRAWING NO C-321867		
			WEIGHT -	CUSTOMER DRAWING	
			SCALE 2:1	SHEET 1 of 1	REV F6